

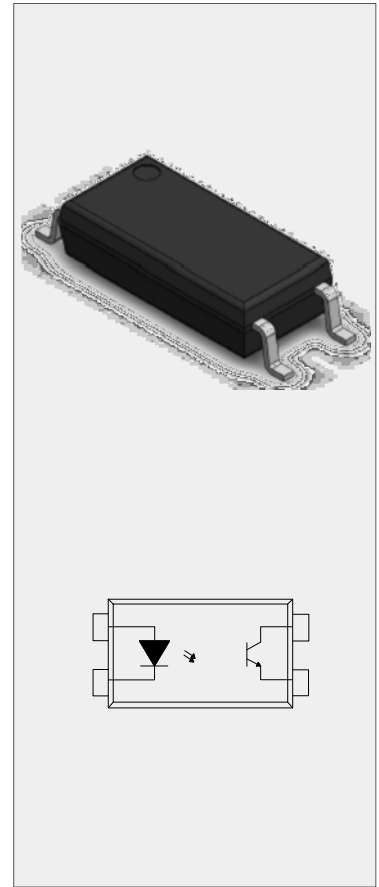

DESCRIPTION:

MAIN FEATURES



ABSOLUTE MAXIMUM RATINGS



NOTE1 100 s pulse, 100Hz frequency

NOTE2 AC for 1minute, R.H.=40~60%

ELECTRICAL CHARACTERISTICS

NOTE1 Rank Table of Current Transfer Ratio (Temperature=25°C)



ORDERING INFORMATION

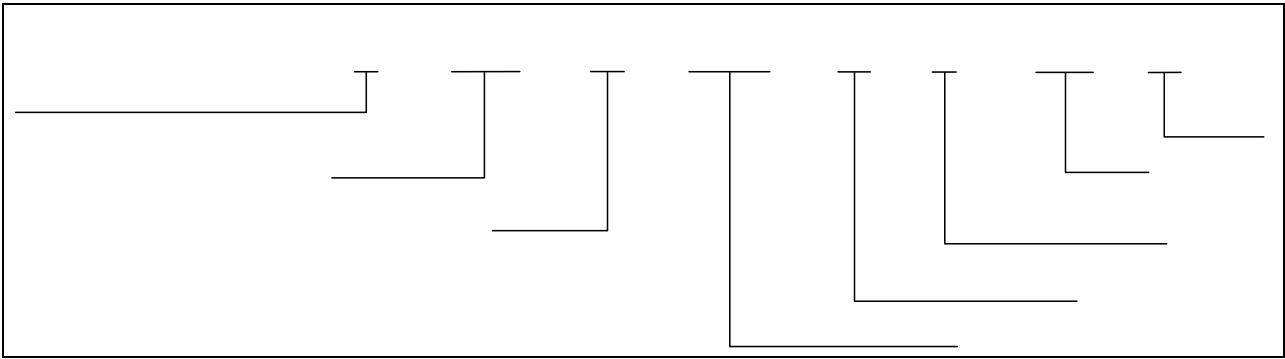

Packing Quantity	
Option	Quantity
None/R	3000 Units/Reel

MARKING

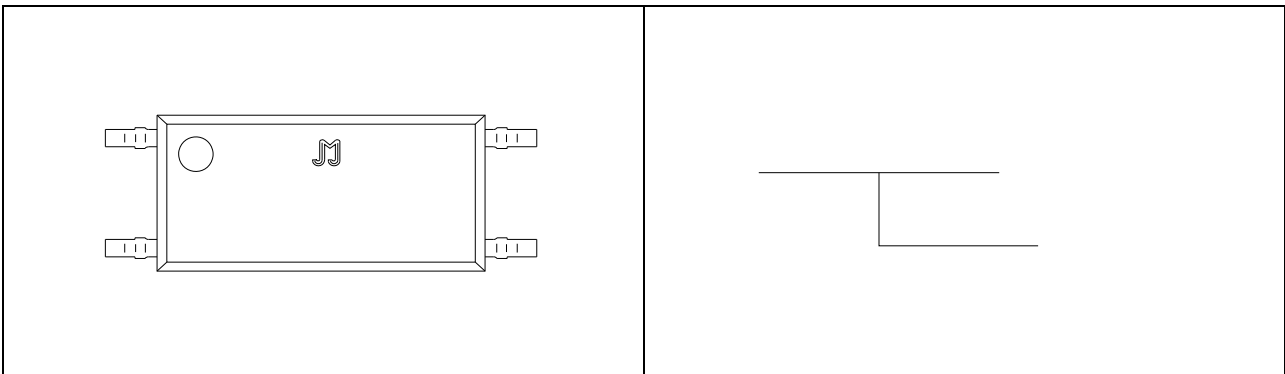



Characteristics Curves

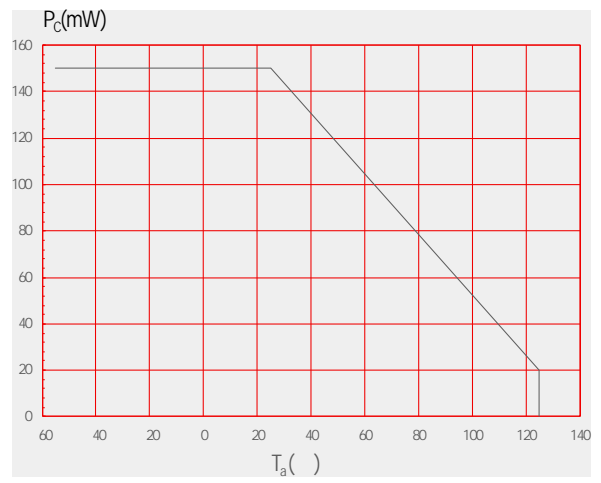
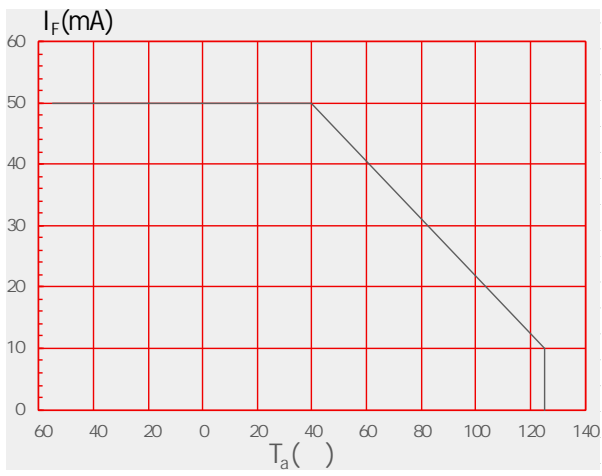

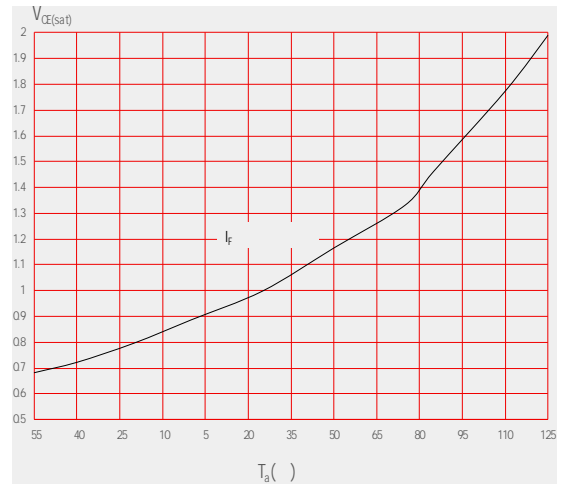
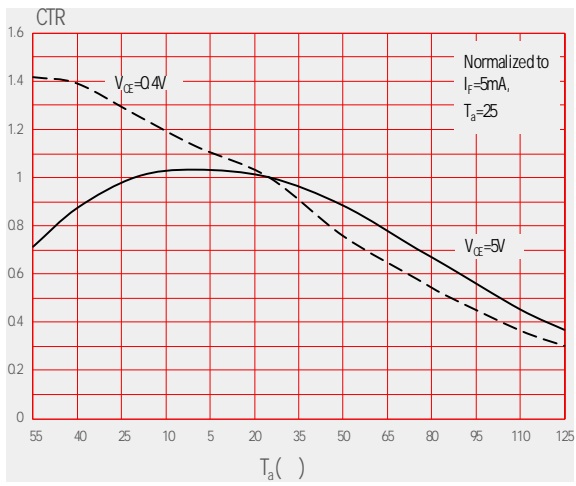



Test Circuits

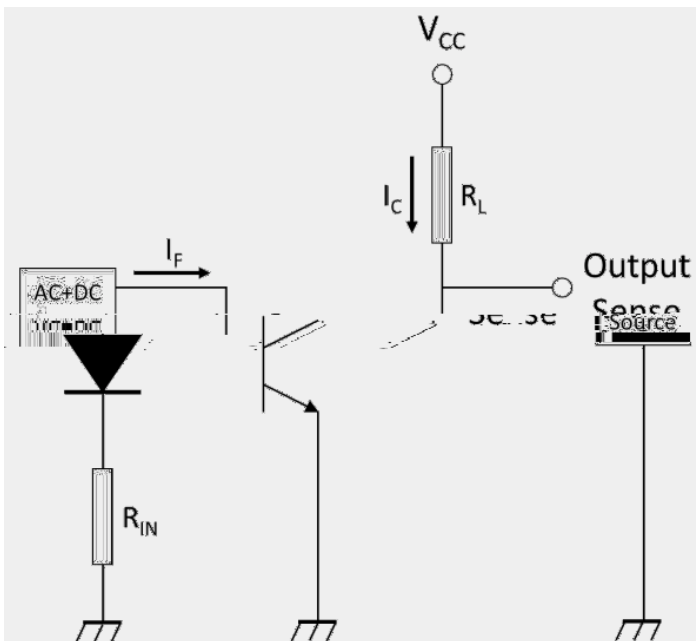
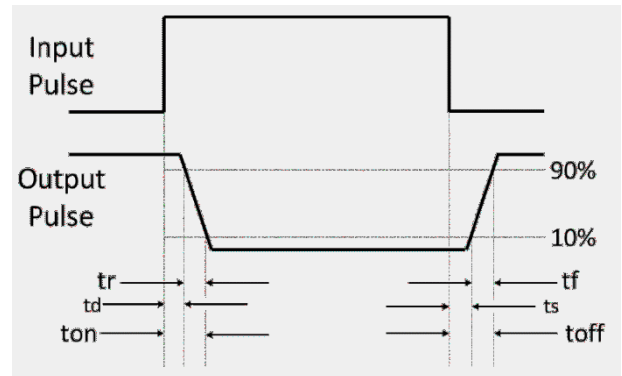
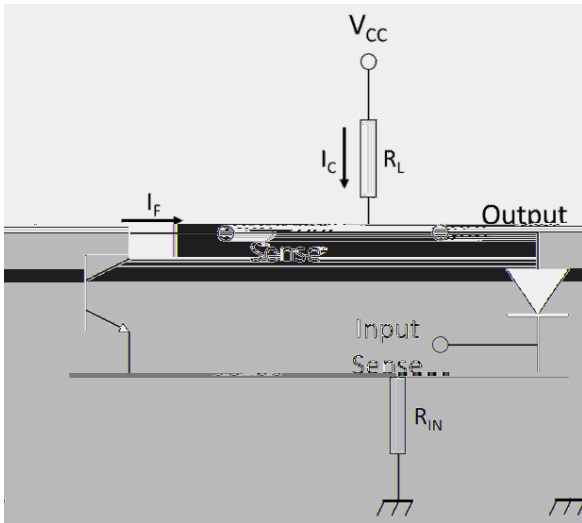



CARRIER TAPE SPECIFICATIONS (Dimensions in mm unless otherwise stated)

Option None/R

