

--	--

NOTE1 100μs pulse, 100Hz frequency

NOTE2 AC for 1 minute, R.H.=40~60%

ELECTRICAL CHARACTERISTICS

Parameter	Symbol	Condition

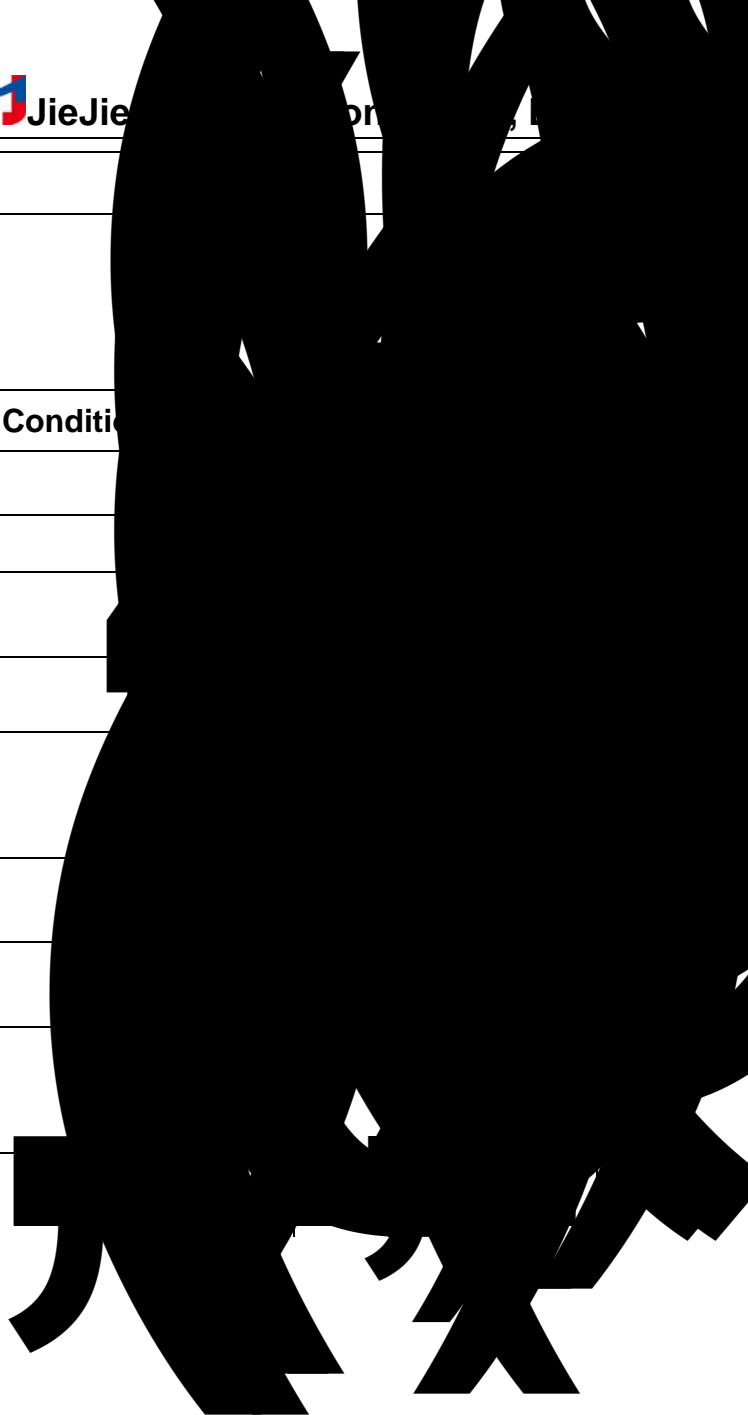

ORDERING INFORMATION

Characteristics Cur

FIG.1:

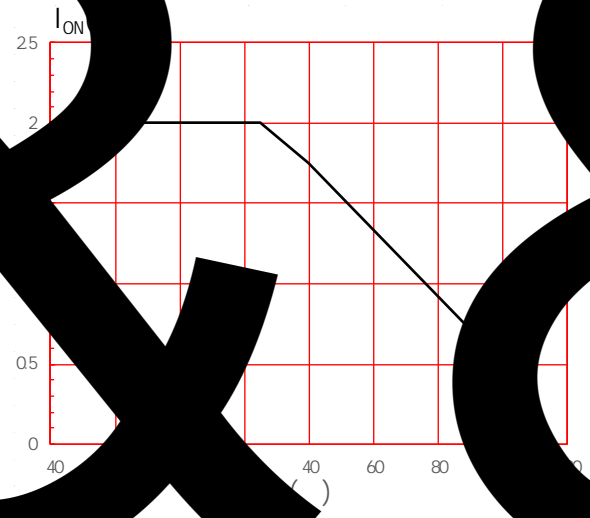
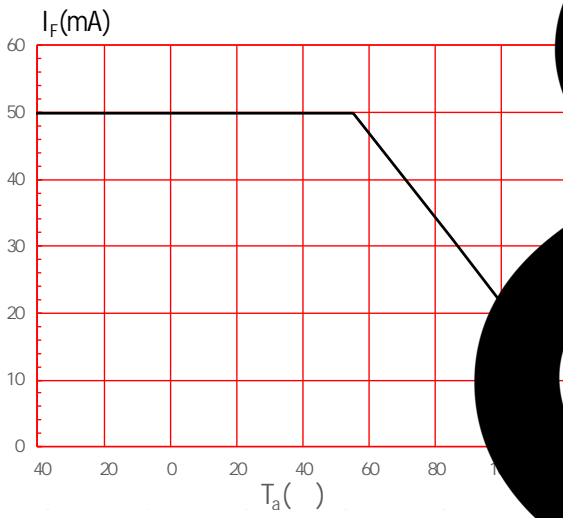

FIG.3:

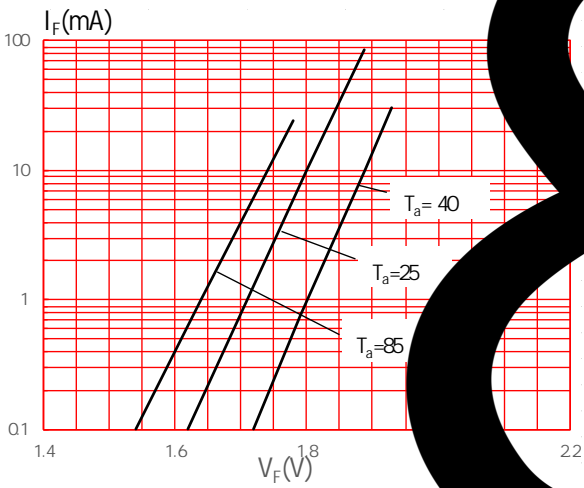

FIG.4:

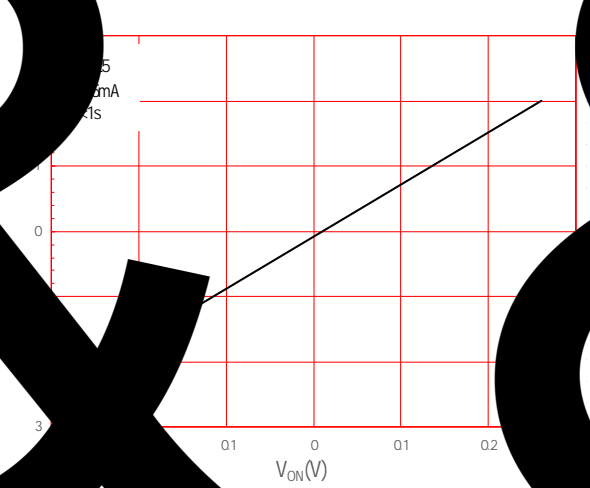

FIG.5:

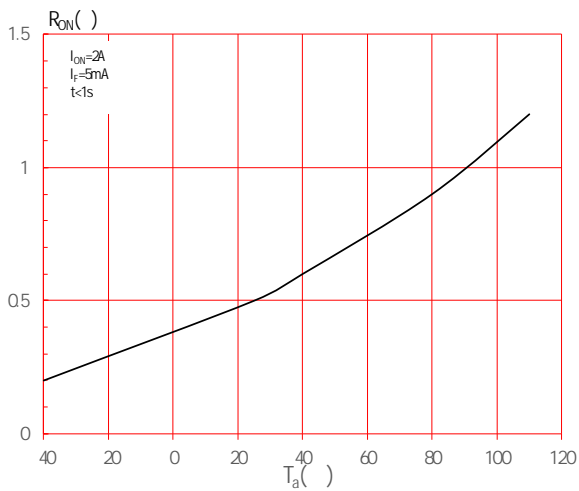

FIG.6:

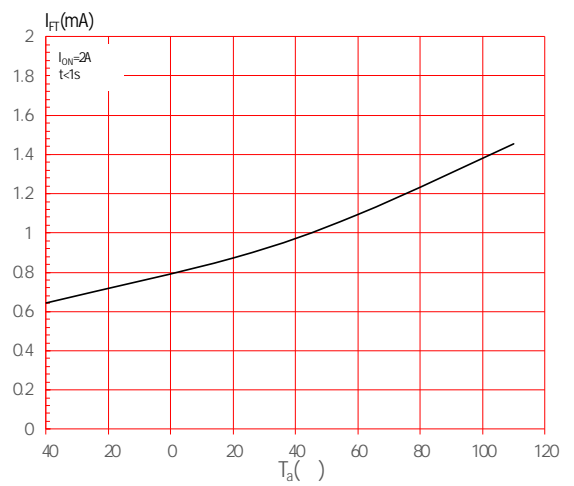

FIG.7:

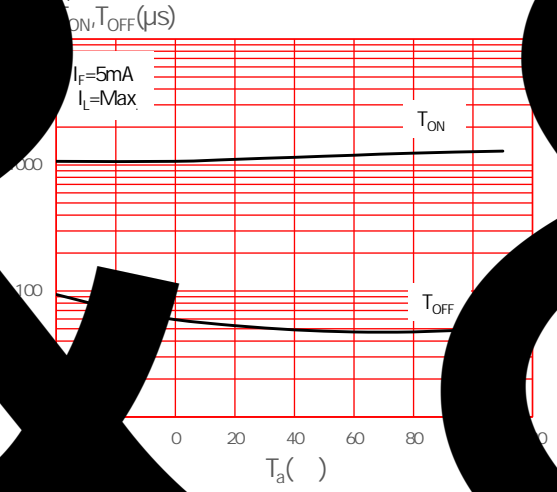
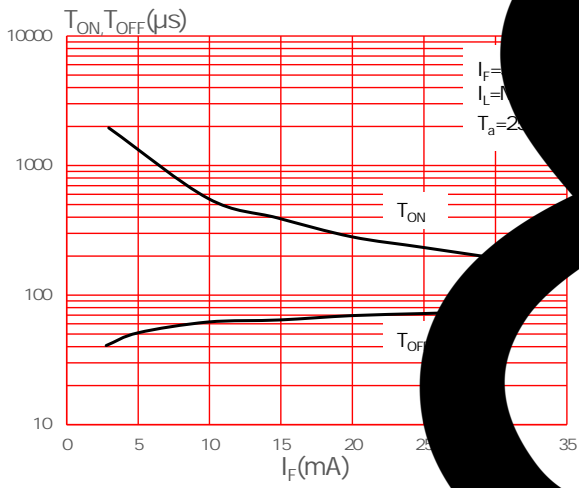

FIG.9:

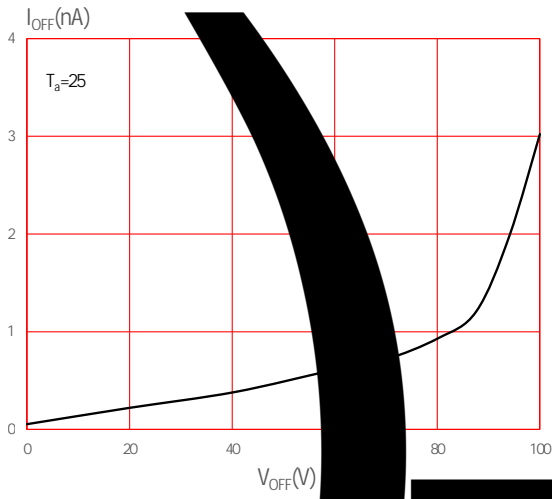

FIG.10:

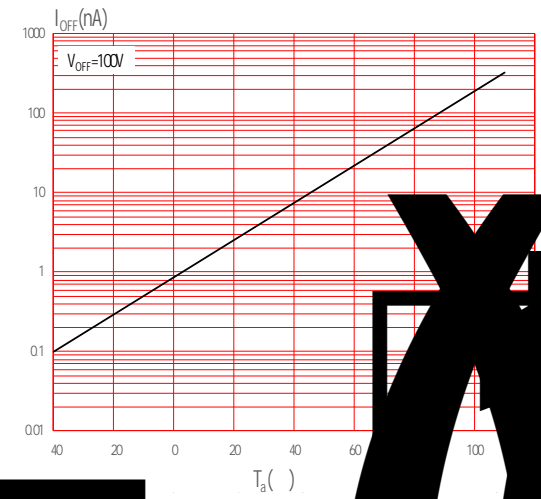
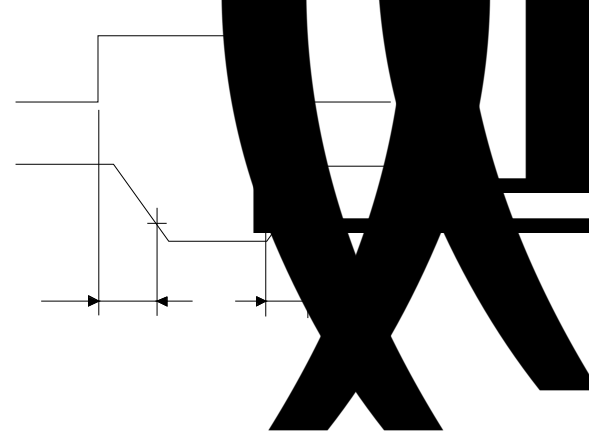
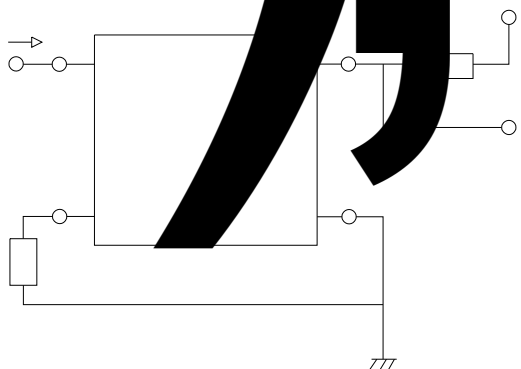
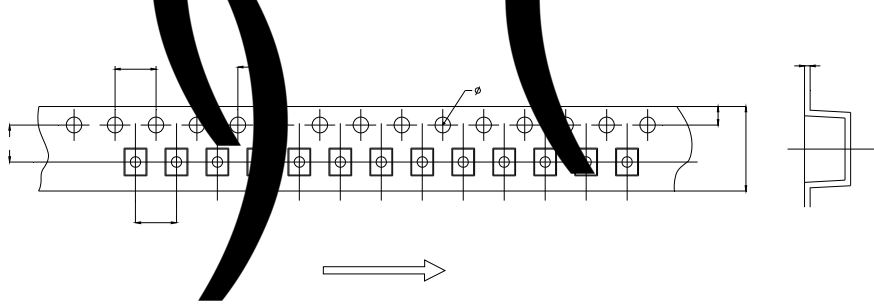

Fig.11: Switching Time Circuit and Wave



CARRIER TYPE SPECIFICATIONS (Dimensions in mm unless otherwise specified)



A grid table with 4 columns and 10 rows, partially obscured by a black redaction mark.

REFLOW INFORMATION

