



DESCRIPTION:

°C

MAIN FEATURES

Truth Table

ABSOLUTE MAXIMUM RATINGS

Parameter		Symbol	Value	Unit
			①	
			②	
				°C
				°C
				°C
				°C

NOTE1 : 100 s pulse, 100Hz frequency

NOTE2 : AC for 1minute, R.H.=40~60%

ELECTRICAL CHARACTERISTICS

Parameter		Symbol	Condition	Min.	Typ.	Max.	Unit

ORDERING INFORMATION

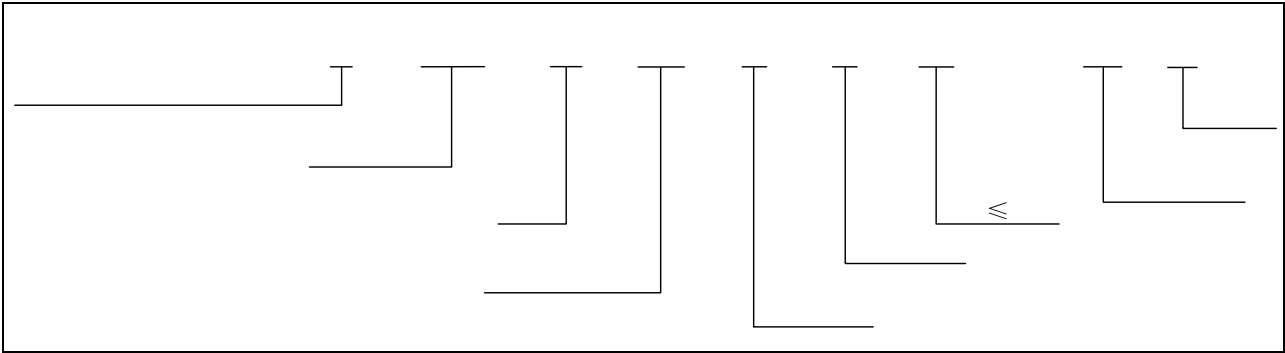

Packing Quantity	
Option	Quantity
None/R	3000 Units/Reel

MARKING

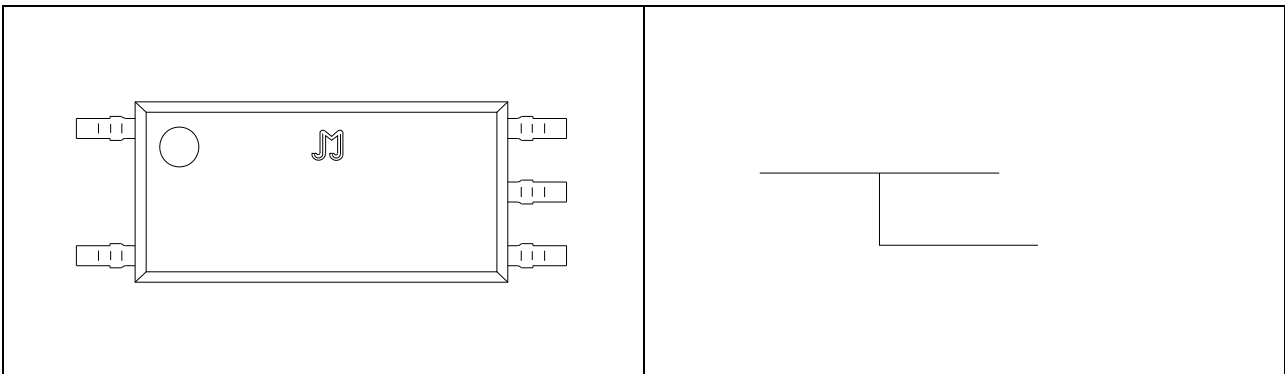

Characteristics Curves

FIG.1:

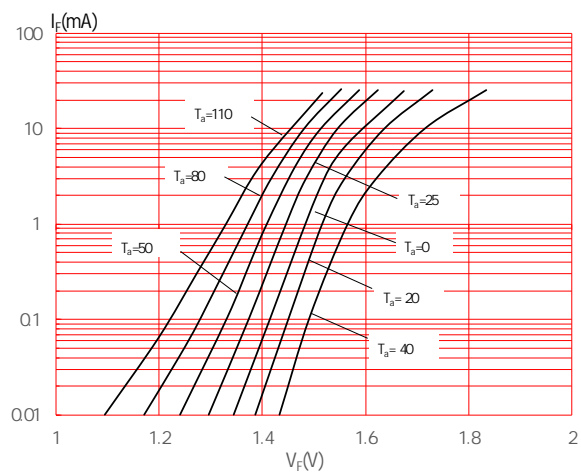

FIG.2:

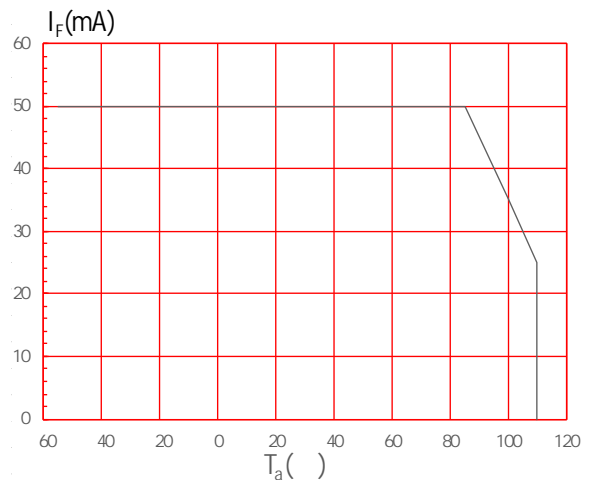

FIG.3:

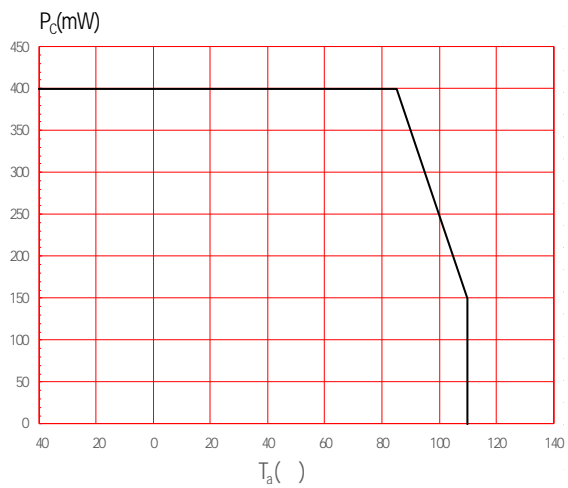

FIG.4:

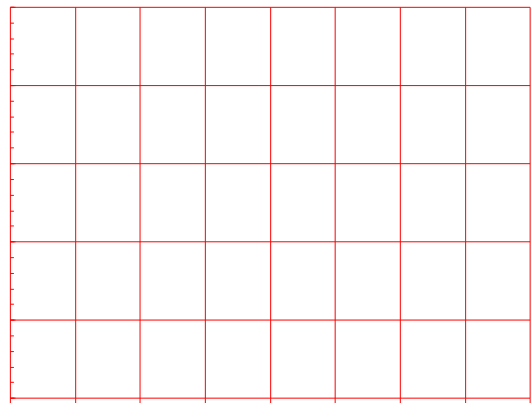

FIG.7:

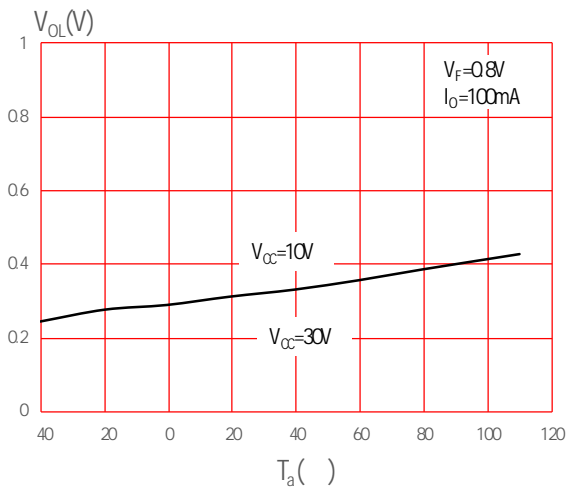

FIG.8:

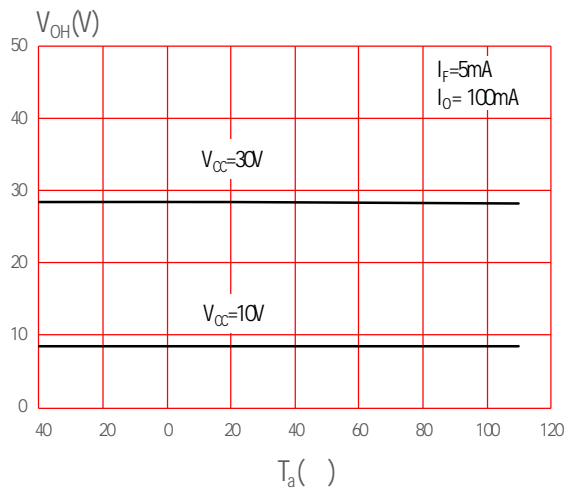

FIG.9:

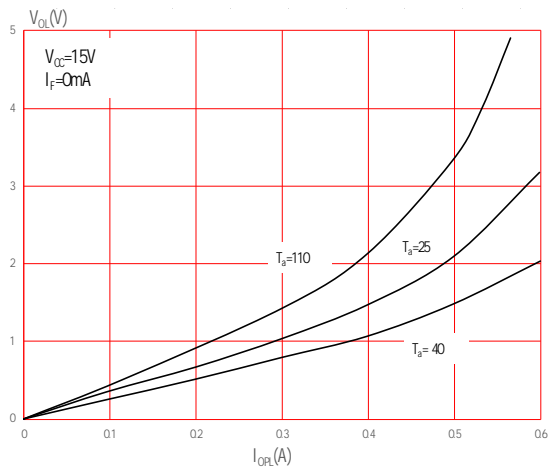

FIG.10:

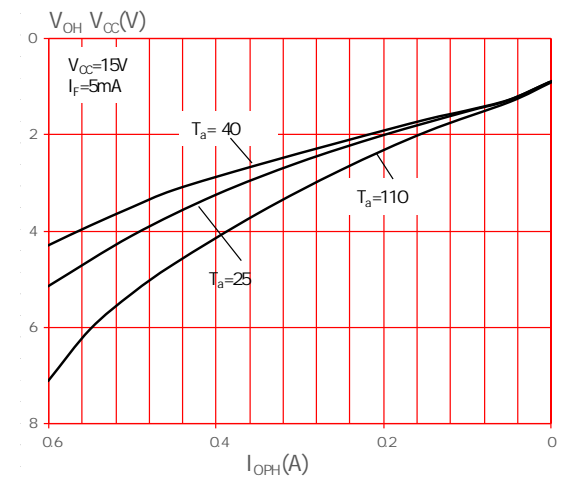

FIG.11:

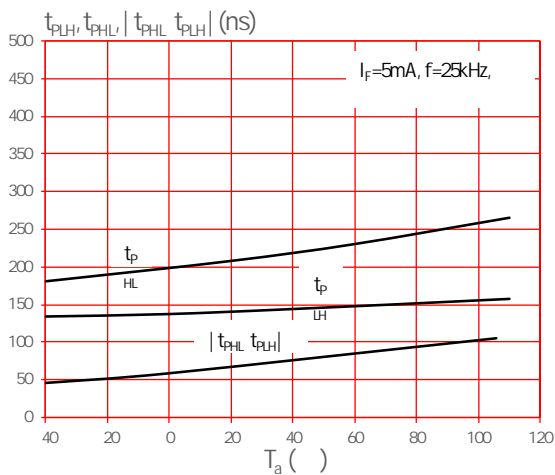

FIG.12:

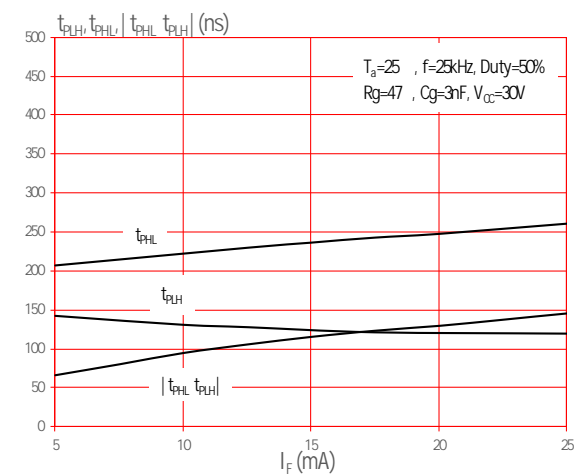
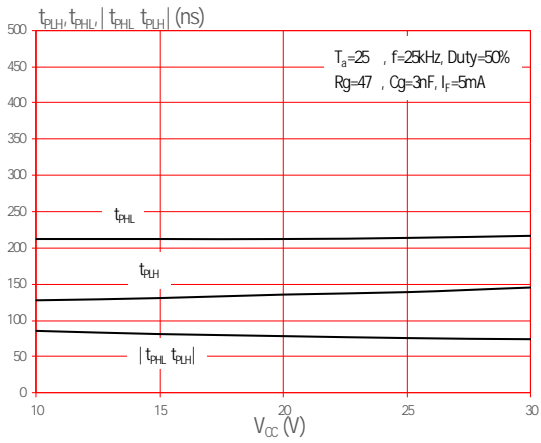

FIG.13:



Test Circuits

FIG.14:

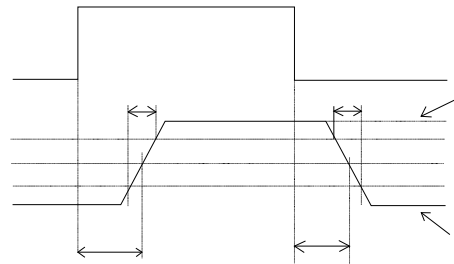
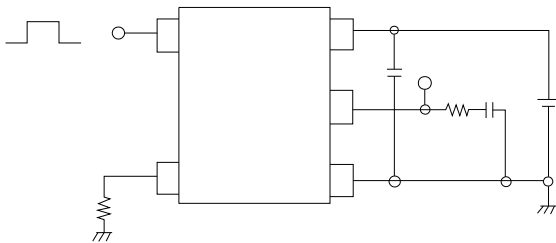
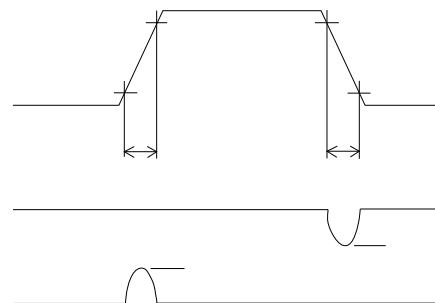
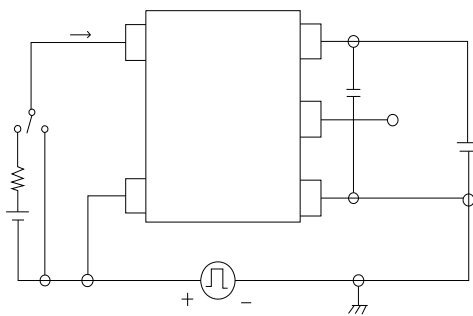
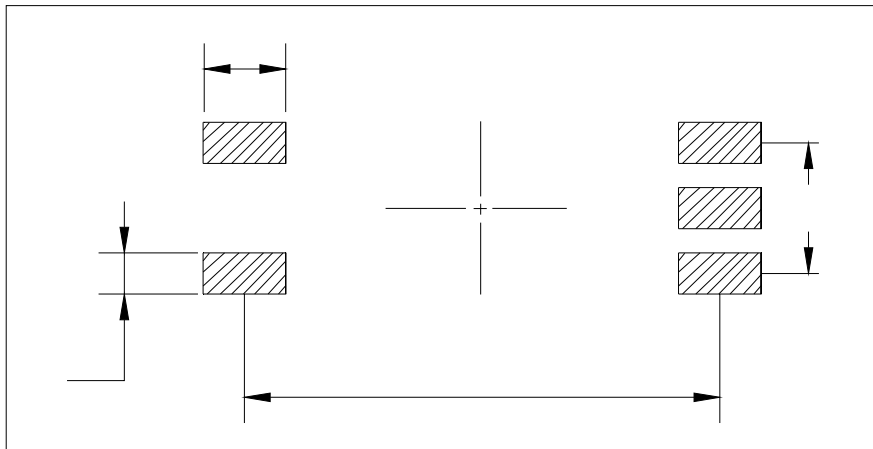

FIG.15:



RECOMMENDED SOLDER MASK (Dimensions in mm unless otherwise stated)

LSOP5



LSOP5W

